



PicSight.com

P142M-Smart

Smart GigE monochrome Camera

- 1/2 inch progressive scan CCD
- 1392 × 1040 square pixels
- 8 fps, 12-bit image data
- high sensitivity
- async reset, full frame shutter
- trigger in, strobe out, video out (CVBS)
- 32-bit RISC processor
- real-time operating system





1/2" CCD Sensor	SONY ICX205
Readout	interline transfer
Sensor size (H×V)	7.6 × 6.2 mm
Output image resolution (H×V)	1392 × 1040 pixels
Pixel size	4.65 × 4.65 μm
Color	monochrome
Scan	progressive
Frame rate	8 frames/sec
Shutter	global
Max. shutter time	20 ms
Min. shutter time	10 μs
Lens mount	C-mount
Optional lens mount	90-degree C-mount

Spectral sensitivity

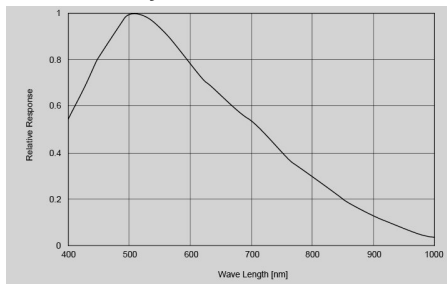

Interface

Ethernet	10/100/1000 Mbit/sec
Memory	64 MB DDR-SDRAM, 32 MB Flash
Status control	Status LED
Digital input	2× Optocoupler, 1× TTL
Digital output	4× Optocoupler
Power input	P142M-Smart-Ax: 10-26 V P142M-Smart: 12 V
Power consumption	6 W
Weight	133 g
Operating temperature	0–50 °C

Embedded software

API	Image acquisition, camera & video out control, file system, GigE/RS232 comm, drawing library
Compiler/OS	C, C++/Real-time OS
Host (PC) software	
API LV-SDS	C, C++, OCX, .Net
3rd party	Halcon, AVT, Twain, NeuroCheck, VFW
Configuration	Web interface
Firmware update	FTP

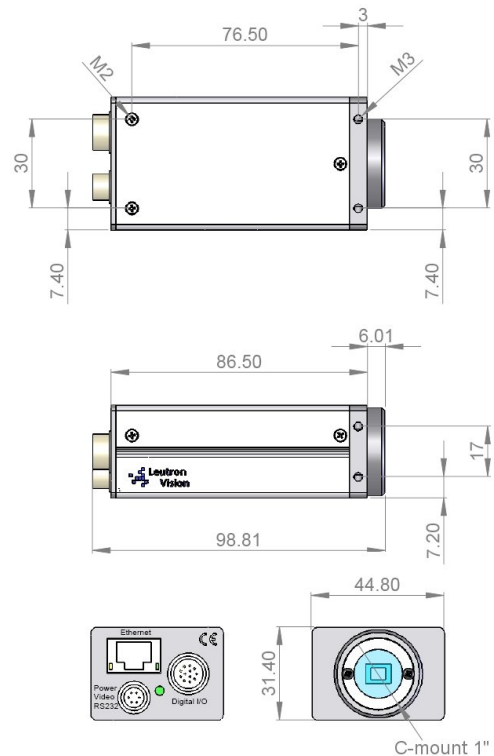

Hirose 12-pin connector, male, HR10A-10R-12PB-71		Hirose 6-pin connector, male, HR10A-7R-6PB-73	
Pin	Signal	Pin	Signal
1	Opto Output Tap	1	TXD Output
2	Opto Output Common Emitter	2	RXD Input
3	Opto Output Collector 0	3	Ground
4	Opto Output Collector 1	4	Video Out (CVBS)
5	Opto Output Collector 2	5	Ground
6	P142M-Smart-Ax: TTL output , P142M-Smart: Opto Output Collector 3	6	Power Input
7	Power Input		
8	Opto Input 1		
9	Opto Input 0		
10	Opto Input Common		
11	Trigger Input TTL		
12	Ground		

Ordering numbers

Number	Product name	Option
160500	PicSight P142M-GigE-Smart501	
81005901	Tripod	Mounting plate for camera
16028	LV-SDS	Software API

International headquarters Switzerland
 Leutron Vision AG
 Industriestrasse 57
 CH-8152 Glattbrugg, Switzerland
 Phone ++41 44 809 88 22
 fax ++41 44 809 88 29
 intsales@leutron.com
www.leutron.com

Germany
 Leutron Vision GmbH
 Macairestrasse 3
 D-78467 Konstanz, Germany
 Phone ++49 7531 5942 0
 fax ++49 7531 594299
 desales@leutron.com
www.leutron-vision.de

North America
 Leutron Vision Inc.
 25 Mall Road – Suite 300
 Burlington, MA 01803, USA
 Phone: ++1 888 442 2269 x1
 Fax: ++1 781 353 3943
 ussales@leutron.com
www.leutron.com/us/

